

# TEXAS DEPARTMENT OF INSURANCE

Engineering Services Program / MC 103-3A 333 Guadalupe Street P.O. Box 149104 Austin, Texas 78714-9104  
Phone No. (512) 322-2212 Fax No. (512) 463-6693

---

## PRODUCT EVALUATION RC-20

Effective Date: July 1, 2014

*The following product has been evaluated for compliance with the wind loads specified in the **International Residential Code (IRC)** and the **International Building Code (IBC)**. This product shall be subject to reevaluation **August 2015**.*

*This product evaluation is not an endorsement of this product or a recommendation that this product be used. The Texas Department of Insurance has not authorized the use of any information contained in the product evaluation for advertising, or other commercial or promotional purpose.*

*This product evaluation is intended for use by those individuals who are following the design wind load criteria in Chapter 3 of the IRC and Section 1609 of the IBC. The design loads shall not exceed the allowable wind loads shown in this product evaluation. This product evaluation does not relieve a Texas licensed engineer of his responsibilities as outlined in the Texas Insurance Code, the Texas Administrative Code and the Texas Engineering Practice Act.*

**Extruded Interlocking Concrete Roofing Tiles** manufactured by

**Boral Roofing, LLC**  
**7575 Irvine Center Drive**  
**Suite 100**  
**Irvine, California 92618**  
**Telephone: (949) 756-1605**  
**[www.boralna.com](http://www.boralna.com)**

will be accepted for use in designated catastrophe areas along the Texas Gulf Coast when installed in accordance with this product evaluation report, the building specifications adopted by the Texas Department of Insurance, and the manufacturer's installation instructions as referenced in the document entitled "Concrete and Clay Roof Tile Design Criteria Installation Manual for Moderate Climate Regions," March, 2010, published by the Tile Roofing Institute and the Western States Roofing Contractors Association (referred to as the TRI/WSRCA Installation Manual in this evaluation report) except for the attachment methods, which are specified in Tables 3 through 11 of this evaluation report.

## PRODUCT DESCRIPTION

This evaluation report covers extruded concrete roofing tiles that are interlocking. The interlocking tiles have interlocking ribs on the longitudinal edges of the tiles. The interlocking ribs restrict lateral movement and provide a water stop. The tiles are available in a variety of colors.

**Mechanical Attachment:** The concrete roofing tiles specified in this evaluation report are to be installed mechanically with fasteners. The roofing tiles may be secured either directly to the roof deck or over battens.

**Adhesive Set Systems:** The Boral Roofing LLC roof tiles may be installed with roof tile adhesives that are either recognized in a current ICC-ES evaluation report for use in concrete roof tile applications or are specified in a Texas Department of Insurance evaluation report. Installation of tiles using these adhesive set systems must be in accordance with the adhesive manufacturers' ICC-ES evaluation reports and must comply with the building specifications adopted by the Texas Department of Insurance or must be in accordance with a Texas Department of Insurance evaluation report. Adhesive set tile installations are outside the scope of this evaluation report.

**Roofing Tile Profile Classifications:** Roofing tile profiles shall be classified as one of the following:

**Flat/Low profile:** Flat/Low profile tiles are defined as tiles having a rise equal to or less than  $\frac{1}{2}$  inch.

**Medium profile:** Medium profile tiles are defined as tiles having a rise greater than  $\frac{1}{2}$  inch and a rise to width ratio of less than or equal to 1.5.

**High/Barrel profile:** High profile tiles are defined as those tiles having a rise to width ratio greater than 1.5.

**Tile Weight:** This evaluation report covers standard weight tiles. Lightweight tiles are outside of the scope of this evaluation report.

**Roofing Tile Designations, Profile Classifications, and Dimensions:** The roofing tile designations, profile classifications, and dimensions for the roofing tiles that apply to this product evaluation report are specified in Table 1. A picture of each roofing tile is shown in Figures 1 through 5 at the end of this evaluation report.

**Table 1**  
**Roofing Tile Designations, Profile Classifications, and Dimensions**

Tile Designation	Profile Classification	Tile Length (in.)	Tile Width (in.)
Saxony Shake and Slate	Flat/Low	16 $\frac{1}{2}$	13
Saxony Country Slate-Impact	Flat/Low	16 $\frac{1}{2}$	13
Madera	Flat/Low	13 $\frac{1}{2}$	13
Villa	Medium	16 $\frac{1}{2}$	13
Tejas Espana	High	16 $\frac{1}{2}$	13
Barcelona - Impact	High	16 $\frac{1}{2}$	13

### INSTALLATION INSTRUCTIONS and LIMITATIONS

**Roof Framing and Roof Deck:** Roof framing members shall be in accordance with either the International Residential Code or the International Building Code. The roof framing members shall not be spaced greater than 24 inches on center. The roof deck shall be solidly sheathed with minimum  $\frac{15}{32}$ " plywood. The roof deck shall be fastened to the roof framing members in accordance with either the International Residential Code or the International Building Code to resist the required wind loads.

If the existing roof deck is a spaced board roof deck, then the spaced boards shall either be removed or covered with minimum  $\frac{15}{32}$ " plywood. The plywood sheathing shall be installed over the spaced boards in accordance with either the International Residential Code or the International Building Code to resist the required wind loads.

**Metal drip edge:** A metal drip edge shall be installed as specified in the manufacturer's installation instructions as referenced in the TRI/WSRCA Installation Manual.

**Roof underlayment:**

**2 ½ :12 roof slope to under 4:12 roof slope:** Single-ply or multi-ply sealed underlayment system with sealed head laps and side laps. The underlayment shall be installed as specified in either the International Residential Code or the International Building Code and in the manufacturer's installation instructions as referenced in the TRI/WSRCA Installation

**4:12 roof slope and greater:** One layer of underlayment complying with ASTM D 226, Type II (No. 30 asphalt felt) or equivalent. The underlayment shall be lapped a minimum of 2 inches at the head laps and a minimum of 6 inches at the side laps. The underlayment shall be installed as specified in either the International Residential Code or the International Building Code and in the manufacturer's installation instructions as referenced in the TRI/WSRCA Installation Manual.

**Battens:** The roofing tiles may be installed over battens. For roof slopes greater than 7:12, battens are required. The roof deck shall be solidly sheathed with minimum 1 5/32" plywood when battens are used. As a minimum, the battens shall be nominal 1x2 wood members. NOTE: For the Madera roofing tiles, nominal 1x3 wood members are required. The battens shall be spaced to allow for a minimum 3 inch headlap. The battens shall be fastened to the roof deck with minimum 8d corrosion resistant common wire or box nails or equivalent size nail. The nails shall be spaced a maximum of 24 inches on center. As an alternative, battens may be fastened to the roof deck with No. 16 gauge by 7/16" crown by 1 ½" long staples. The staples shall be spaced a maximum of 12 inches on center. Batten ends shall be separated a minimum of ½" every 4 feet to allow for drainage. Refer to Tables 4, 6, 8 and 10 for roofing tiles installed over battens.

**Roofing Tile Installation:** The limitations on mean roof height and roof slope for installing the roofing tiles shall be in accordance with the following guidelines:

**Roof Slope Limitations:** The roofing tiles shall only be installed on buildings with a roof slope of 2 ½ :12 or greater. Specific roof slope limitations are specified in Tables 3 through 11. **Note:** Battens are required when the roof slope exceeds 7:12. At a roof slope greater than 24:12 from the horizontal, the nose end of all tiles shall be fastened to the roof deck with a nose clip.

**Mean Roof Height Limitations:** The mean roof height limitations for installing the roofing tiles shall be as specified in Tables 3 through 11 for buildings with a mean roof height of 60 feet or less. For buildings with a mean roof height greater than 60 feet, the roofing tiles and their fastening systems shall be designed to withstand the aerodynamic wind uplift moment determined in accordance with Section 1609.7.3 of the IBC.

**General:** The roofing tiles and the underlayment system shall be clean and dry at the time of their application.

The roofing tiles shall be installed in accordance with this product evaluation report and the manufacturer's installation instructions as referenced in the TRI/WSRCA Installation Manual.

The roofing tiles shall be laid out from the right to the left, starting at the right rake. The roofing tiles shall be installed with a minimum 3 inch headlap.

**NOTE:** When battens are used, the batten fasteners shall be long enough to penetrate a minimum of ¾" into and through the roof deck.

**Roofing Tile Fasteners:** The roofing tiles shall be mechanically fastened to the roof deck. The follow fasteners are acceptable:

**Minimum No. 8 course-threaded screw(s).** The screws shall be minimum 2 ½" long, bugle head screws conforming to ANSI/ASME 8.18.6.1, having a nominal diameter of 0.335", a shank diameter of 0.131", and a screw thread diameter of 0.175". The fasteners must be long enough to penetrate a minimum of ¾" into or through the roof deck.

**Minimum 10d ring shank nails.** The 10d ring shank nails shall be minimum 3" long, 0.283" flat head diameter, having a 0.121" shank diameter and a 0.131" ring shank diameter. The fasteners must be long enough to penetrate a minimum of ¾" into or through the roof deck.

**Roofing Tile Fastener Locations:** Fastener hole locations are shown for each roofing tile in Figures 1 through 5. The holes marked "A" and "B" in Figures 1 through 5 shall be used when two fasteners are required. When one fastener is required, the hole marked "B" in Figures 1, 2, 3 and 5 shall be used and the hole marked "C" in Figure 4 (Madera roofing tile) shall be used.

**Rake Tiles:** Rake tiles shall be secured to minimum Spruce-Pine-Fir lumber framing with either two (2) minimum No. 8 screws or two (2) minimum 10d ring shank nails. The corrosion resistant fasteners shall be long enough to penetrate the wood framing a minimum ¾ inch.

**Hip and Ridge Tiles:** The hip and ridge tiles shall be fastened to hip and ridge boards (Dimension lumber of sufficient height to support the hip and ridge tiles) in accordance with one of the following options:

- (1) Drill a ⅜" hole in the lower 1/3 of the starter tile. Use a fastener as specified in Table 2 and secure the starter tile at both the drilled hole in the lower 1/3 and at the head of the tile. Seal the head of the fastener with a UV resistant sealant.
- (2) Prior to installing the starter tile, apply a roof tile adhesive along the entire length of the starter tile. Secure the head of the starter tile with a fastener as specified in Table 2.

The remaining hip and ridge tiles are to be installed with a minimum 2 inch headlap. Place the nose of the tile into a 4" to 5" bead of roof tile adhesive along the head of the lower tile to insure proper contact with the two tiles. The head of the hip or ridge tile is to be secured using a fastener as specified in Table 2.

**Table 2**  
**Hip and Ridge Tile Fastener Requirements**

Dimension lumber	Fasteners per Tile
Spruce-Pine-Fir	One (1) No. 8 screw
Southern Yellow Pine	One (1) No. 8 screw

**Note:** A copy of the manufacturer's installation instructions as referenced in the TRI/WSRCA Installation Manual shall be available at the job site. All fasteners shall be corrosion resistant as specified in the International Residential Code (IRC), the International Building Code (IBC), and the Texas Revisions.

**Table 3**  
**Saxony Slate and Shake, Madera**  
**(Roof Deck: Minimum  $1\frac{5}{32}$ " Plywood Deck without Battens)**

<b>Gable Roofs</b>						
<b>Roof Slope: <math>\geq 2\frac{1}{2}</math>:12 and <math>\leq 6</math>:12</b>						
Fastener Requirements	Mean Roof Height Limitation <sup>2</sup>					
	Inland II		Inland I		Seaward	
	Exposure B <sup>1</sup>	Exposure C <sup>1</sup>	Exposure B <sup>1</sup>	Exposure C <sup>1</sup>	Exposure B <sup>1</sup>	Exposure C <sup>1</sup>
One (1) No. 8 screw	60 ft	60 ft	60 ft	60 ft	60 ft	40 ft
Two (2) No. 8 screws	60 ft	60 ft	60 ft	60 ft	60 ft	60 ft
Two (2) 10d Ring Shank Nails	60 ft	60 ft	60 ft	60 ft	60 ft	40 ft
<b>Gable Roofs</b>						
<b>Roof Slope: <math>&gt; 6</math>:12 and <math>\leq 7</math>:12<sup>3</sup></b>						
Fastener Requirements	Mean Roof Height Limitation <sup>2</sup>					
	Inland II		Inland I		Seaward	
	Exposure B <sup>1</sup>	Exposure C <sup>1</sup>	Exposure B <sup>1</sup>	Exposure C <sup>1</sup>	Exposure B <sup>1</sup>	Exposure C <sup>1</sup>
One (1) No. 8 screw	60 ft	60 ft	60 ft	60 ft	60 ft	60 ft
Two (2) No. 8 screws	60 ft	60 ft	60 ft	60 ft	60 ft	60 ft
Two (2) 10d Ring Shank Nails	60 ft	60 ft	60 ft	60 ft	60 ft	60 ft
<b>Monoslope Roofs</b>						
<b>Roof Slope: <math>\geq 2\frac{1}{2}</math>:12 and <math>&lt; 7</math>:12</b>						
Fastener Requirements	Mean Roof Height Limitation <sup>2</sup>					
	Inland II		Inland I		Seaward	
	Exposure B <sup>1</sup>	Exposure C <sup>1</sup>	Exposure B <sup>1</sup>	Exposure C <sup>1</sup>	Exposure B <sup>1</sup>	Exposure C <sup>1</sup>
One (1) No. 8 screw	60 ft	60 ft	60 ft	60 ft	60 ft	25 ft
Two (2) No. 8 screws	60 ft	60 ft	60 ft	60 ft	60 ft	60 ft
Two (2) 10d Ring Shank Nails	60 ft	60 ft	60 ft	60 ft	60 ft	25 ft

Note: <sup>1</sup> The Exposure category for the structure location shall be as defined in either the International Residential Code or the International Building Code.

<sup>2</sup> Table is based on an Importance factor of 1.0

<sup>3</sup> Roof slopes greater than 7:12 require battens

**Table 4**  
**Saxony Slate and Shake, Madera**<sup>4</sup>  
**(Roof Deck: Minimum 1 5/32" Plywood Deck with Battens)**

<b>Gable Roofs</b>						
<b>Roof Slope: <math>\geq 2 \frac{1}{2}</math>:12 and <math>\leq 6</math>:12</b>						
Fastener Requirements	Mean Roof Height Limitation <sup>2</sup>					
	Inland II		Inland I		Seaward	
	Exposure B <sup>1</sup>	Exposure C <sup>1</sup>	Exposure B <sup>1</sup>	Exposure C <sup>1</sup>	Exposure B <sup>1</sup>	Exposure C <sup>1</sup>
One (1) No. 8 screw	60 ft	25 ft	50 ft	N/A	N/A	N/A
Two (2) No. 8 screws	60 ft	60 ft	60 ft	60 ft	60 ft	25 ft
Two (2) Ring Shank Nails	60 ft	20 ft	40 ft	N/A	N/A	N/A
<b>Gable Roofs</b>						
<b>Roof Slope: <math>&gt; 6</math>:12<sup>3</sup></b>						
Fastener Requirements	Mean Roof Height Limitation <sup>2</sup>					
	Inland II		Inland I		Seaward	
	Exposure B <sup>1</sup>	Exposure C <sup>1</sup>	Exposure B <sup>1</sup>	Exposure C <sup>1</sup>	Exposure B <sup>1</sup>	Exposure C <sup>1</sup>
One (1) No. 8 screw	60 ft	60 ft	60 ft	60 ft	60 ft	60 ft
Two (2) No. 8 screws	60 ft	60 ft	60 ft	60 ft	60 ft	60 ft
Two (2) 10d Ring Shank Nails	60 ft	60 ft	60 ft	60 ft	60 ft	40 ft
<b>Monoslope Roofs</b>						
<b>Roof Slope: <math>\geq 2 \frac{1}{2}</math>:12 and <math>&lt; 7</math>:12</b>						
Fastener Requirements	Mean Roof Height Limitation <sup>2</sup>					
	Inland II		Inland I		Seaward	
	Exposure B <sup>1</sup>	Exposure C <sup>1</sup>	Exposure B <sup>1</sup>	Exposure C <sup>1</sup>	Exposure B <sup>1</sup>	Exposure C <sup>1</sup>
One (1) No. 8 screw	60 ft	15 ft	30 ft	N/A	N/A	N/A
Two (2) No. 8 screws	60 ft	60 ft	60 ft	40 ft	60 ft	15 ft
Two (2) 10d Ring Shank Nails	50 ft	15 ft	30 ft	N/A	N/A	N/A

Note: <sup>1</sup> The Exposure category for the structure location shall be as defined in either the International Residential Code or the International Building Code.

<sup>2</sup> Table is based on an Importance factor of 1.0

<sup>3</sup> For roof slopes  $> 24$ :12, the nose end of all tiles shall be fastened to the roof deck with a nose clip.

<sup>4</sup> The Madera roofing tiles require nominal 1" x 3" wood battens

**Table 5**  
**Villa**  
**(Roof Deck: Minimum  $1\frac{5}{32}$ " Plywood Deck without Battens)**

<b>Gable Roofs</b>						
<b>Roof Slope: <math>\geq 2\frac{1}{2}</math>:12 and <math>\leq 6</math>:12</b>						
Fastener Requirements	Mean Roof Height Limitation <sup>2</sup>					
	Inland II		Inland I		Seaward	
	Exposure B <sup>1</sup>	Exposure C <sup>1</sup>	Exposure B <sup>1</sup>	Exposure C <sup>1</sup>	Exposure B <sup>1</sup>	Exposure C <sup>1</sup>
One (1) No. 8 screw	60 ft	60 ft	60 ft	40 ft	60 ft	15 ft
Two (2) No. 8 screws	60 ft	60 ft	60 ft	60 ft	60 ft	60 ft
Two (2) 10d Ring Shank Nails	60 ft	60 ft	60 ft	60 ft	60 ft	25 ft
<b>Gable Roofs</b>						
<b>Roof Slope: <math>&gt; 6</math>:12 and <math>\leq 7</math>:12<sup>3</sup></b>						
Fastener Requirements	Mean Roof Height Limitation <sup>2</sup>					
	Inland II		Inland I		Seaward	
	Exposure B <sup>1</sup>	Exposure C <sup>1</sup>	Exposure B <sup>1</sup>	Exposure C <sup>1</sup>	Exposure B <sup>1</sup>	Exposure C <sup>1</sup>
One (1) No. 8 screw	60 ft	60 ft	60 ft	60 ft	60 ft	60 ft
Two (2) No. 8 screws	60 ft	60 ft	60 ft	60 ft	60 ft	60 ft
Two (2) 10d Ring Shank Nails	60 ft	60 ft	60 ft	60 ft	60 ft	60 ft
<b>Monoslope Roofs</b>						
<b>Roof Slope: <math>\geq 2\frac{1}{2}</math>:12 and <math>&lt; 7</math>:12</b>						
Fastener Requirements	Mean Roof Height Limitation <sup>2</sup>					
	Inland II		Inland I		Seaward	
	Exposure B <sup>1</sup>	Exposure C <sup>1</sup>	Exposure B <sup>1</sup>	Exposure C <sup>1</sup>	Exposure B <sup>1</sup>	Exposure C <sup>1</sup>
One (1) No. 8 screw	60 ft	60 ft	60 ft	25 ft	40 ft	N/A
Two (2) No. 8 screws	60 ft	60 ft	60 ft	60 ft	60 ft	60 ft
Two (2) 10d Ring Shank Nails	60 ft	60 ft	60 ft	40 ft	60 ft	15 ft

Note: <sup>1</sup> The Exposure category for the structure location shall be as defined in either the International Residential Code or the International Building Code.

<sup>2</sup> Table is based on an Importance factor of 1.0

<sup>3</sup> Roof slopes greater than 7:12 require battens

**Table 6**  
**Villa**  
**(Roof Deck: Minimum  $1\frac{5}{32}$ " Plywood Deck with Battens)**

<b>Gable Roofs</b>						
<b>Roof Slope: <math>\geq 2\frac{1}{2}</math>:12 and <math>\leq 6</math>:12</b>						
Fastener Requirements	Mean Roof Height Limitation <sup>2</sup>					
	Inland II		Inland I		Seaward	
	Exposure B <sup>1</sup>	Exposure C <sup>1</sup>	Exposure B <sup>1</sup>	Exposure C <sup>1</sup>	Exposure B <sup>1</sup>	Exposure C <sup>1</sup>
One (1) No. 8 screw	60 ft	50 ft	60 ft	25 ft	50	N/A
Two (2) No. 8 screws	60 ft	60 ft	60 ft	60 ft	60 ft	50 ft
Two (2) 10d Ring Shank Nails	60 ft	60 ft	60 ft	60 ft	60 ft	25 ft
<b>Gable Roofs</b>						
<b>Roof Slope: <math>&gt; 6</math>:12<sup>3</sup></b>						
Fastener Requirements	Mean Roof Height Limitation <sup>2</sup>					
	Inland II		Inland I		Seaward	
	Exposure B <sup>1</sup>	Exposure C <sup>1</sup>	Exposure B <sup>1</sup>	Exposure C <sup>1</sup>	Exposure B <sup>1</sup>	Exposure C <sup>1</sup>
One (1) No. 8 screw	60 ft	60 ft	60 ft	60 ft	60 ft	40 ft
Two (2) No. 8 screws	60 ft	60 ft	60 ft	60 ft	60 ft	60 ft
Two (2) 10d Ring Shank Nails	60 ft	60 ft	60 ft	60 ft	60 ft	60 ft
<b>Monoslope Roofs</b>						
<b>Roof Slope: <math>\geq 2\frac{1}{2}</math>:12 and <math>&lt; 7</math>:12</b>						
Fastener Requirements	Mean Roof Height Limitation <sup>2</sup>					
	Inland II		Inland I		Seaward	
	Exposure B <sup>1</sup>	Exposure C <sup>1</sup>	Exposure B <sup>1</sup>	Exposure C <sup>1</sup>	Exposure B <sup>1</sup>	Exposure C <sup>1</sup>
One (1) No. 8 screw	60 ft	40 ft	60 ft	15 ft	30 ft	N/A
Two (2) No. 8 screws	60 ft	60 ft	60 ft	60 ft	60 ft	30 ft
Two (2) 10d Ring Shank Nails	60 ft	60 ft	60 ft	40 ft	60 ft	20 ft

Note: <sup>1</sup> The Exposure category for the structure location shall be as defined in either the International Residential Code or the International Building Code.

<sup>2</sup> Table is based on an Importance factor of 1.0

<sup>3</sup> For roof slopes  $> 24$ :12, the nose end of all tiles shall be fastened to the roof deck with a nose clip.



**Table 7**  
**Tejas Espana**  
**(Roof Deck: Minimum 1<sup>5</sup>/<sub>32</sub> " Plywood Deck without Battens)**

<b>Gable Roofs</b> <b>Roof Slope: <math>\geq 2\frac{1}{2}</math> :12 and <math>\leq 6</math>:12</b>						
Fastener Requirements	Mean Roof Height Limitation <sup>2</sup>					
	Inland II		Inland I		Seaward	
	Exposure B <sup>1</sup>	Exposure C <sup>1</sup>	Exposure B <sup>1</sup>	Exposure C <sup>1</sup>	Exposure B <sup>1</sup>	Exposure C <sup>1</sup>
One (1) No. 8 screw	60 ft	40 ft	60 ft	20 ft	40 ft	N/A
Two (2) No. 8 screws	60 ft	60 ft	60 ft	60 ft	60 ft	60 ft
Two (2) 10d Ring Shank Nails	60 ft	30 ft	60 ft	20 ft	40 ft	N/A
<b>Gable Roofs</b> <b>Roof Slope: <math>&gt; 6</math>:12 and <math>\leq 7</math>:12<sup>3</sup></b>						
Fastener Requirements	Mean Roof Height Limitation <sup>2</sup>					
	Inland II		Inland I		Seaward	
	Exposure B <sup>1</sup>	Exposure C <sup>1</sup>	Exposure B <sup>1</sup>	Exposure C <sup>1</sup>	Exposure B <sup>1</sup>	Exposure C <sup>1</sup>
One (1) No. 8 screw	60 ft	60 ft	60 ft	60ft	60 ft	30 ft
Two (2) No. 8 screws	60 ft	60 ft	60 ft	60 ft	60 ft	60 ft
Two (2) 10d Ring Shank Nails	60 ft	60 ft	60 ft	60 ft	60 ft	60 ft
<b>Monoslope Roofs</b> <b>Roof Slope: <math>\geq 2\frac{1}{2}</math> :12 and <math>&lt; 7</math>:12</b>						
Fastener Requirements	Mean Roof Height Limitation <sup>2</sup>					
	Inland II		Inland I		Seaward	
	Exposure B <sup>1</sup>	Exposure C <sup>1</sup>	Exposure B <sup>1</sup>	Exposure C <sup>1</sup>	Exposure B <sup>1</sup>	Exposure C <sup>1</sup>
One (1) No. 8 screw	60 ft	30 ft	50 ft	N/A	30 ft	N/A
Two (2) No. 8 screws	60 ft	60 ft	60 ft	60 ft	60 ft	60 ft
Two (2) 10d Ring Shank Nails	60 ft	30 ft	50 ft	N/A	30 ft	N/A

Note: <sup>1</sup> The Exposure category for the structure location shall be as defined in either the International Residential Code or the International Building Code.

<sup>2</sup> Table is based on an Importance factor of 1.0

<sup>3</sup> Roof slopes greater than 7:12 require battens

**Table 8**  
**Tejas Espana**  
**(Roof Deck: Minimum  $1\frac{5}{32}$ " Plywood Deck with Battens)**

<b>Gable Roofs</b> <b>Roof Slope: <math>\geq 2\frac{1}{2}</math>:12 and <math>\leq 6</math>:12</b>						
Fastener Requirements	Mean Roof Height Limitation <sup>2</sup>					
	Inland II		Inland I		Seaward	
	Exposure B <sup>1</sup>	Exposure C <sup>1</sup>	Exposure B <sup>1</sup>	Exposure C <sup>1</sup>	Exposure B <sup>1</sup>	Exposure C <sup>1</sup>
One (1) No. 8 screw	60 ft	25 ft	40 ft	N/A	N/A	N/A
Two (2) No. 8 screws	60 ft	60 ft	60 ft	60 ft	60 ft	30 ft
Two (2) 10d Ring Shank Nails	60 ft	30 ft	50 ft	N/A	30 ft	N/A
<b>Gable Roofs</b> <b>Roof Slope: <math>&gt; 6</math>:12<sup>3</sup></b>						
Fastener Requirements	Mean Roof Height Limitation <sup>2</sup>					
	Inland II		Inland I		Seaward	
	Exposure B <sup>1</sup>	Exposure C <sup>1</sup>	Exposure B <sup>1</sup>	Exposure C <sup>1</sup>	Exposure B <sup>1</sup>	Exposure C <sup>1</sup>
One (1) No. 8 screw	60 ft	60 ft	60 ft	40 ft	60 ft	20 ft
Two (2) No. 8 screws	60 ft	60 ft	60 ft	60 ft	60 ft	60 ft
Two (2) 10d Ring Shank Nails	60 ft	60 ft	60 ft	60 ft	60 ft	60 ft
<b>Monoslope Roofs</b> <b>Roof Slope: <math>\geq 2\frac{1}{2}</math>:12 and <math>&lt; 7</math>:12</b>						
Fastener Requirements	Mean Roof Height Limitation <sup>2</sup>					
	Inland II		Inland I		Seaward	
	Exposure B <sup>1</sup>	Exposure C <sup>1</sup>	Exposure B <sup>1</sup>	Exposure C <sup>1</sup>	Exposure B <sup>1</sup>	Exposure C <sup>1</sup>
One (1) No. 8 screw	60 ft	15 ft	30 ft	N/A	N/A	N/A
Two (2) No. 8 screws	60 ft	60 ft	60 ft	40 ft	60 ft	20 ft
Two (2) 10d Ring Shank Nails	60 ft	20 ft	40 ft	N/A	N/A	N/A

Note: <sup>1</sup> The Exposure category for the structure location shall be as defined in either the International Residential Code or the International Building Code.

<sup>2</sup> Table is based on an Importance factor of 1.0

<sup>3</sup> For roof slopes  $> 24$ :12, the nose end of all tiles shall be fastened to the roof deck with a nose clip.

**Table 9**  
**Saxony Country Slate-Impact**  
**(Roof Deck: Minimum 15/32" Plywood Deck – Direct Deck Installation)**

Gable/Hip Roofs Roof Slope: $\geq 2 \frac{1}{2} : 12$ and $\leq 6:12$						
Fastener Requirements	Mean Roof Height Limitation <sup>2</sup>					
	Inland II		Inland I		Seaward	
	Exposure B <sup>1</sup>	Exposure C <sup>1</sup>	Exposure B <sup>1</sup>	Exposure C <sup>1</sup>	Exposure B <sup>1</sup>	Exposure C <sup>1</sup>
Two (2) 10d nails	60 ft	30 ft	50 ft	NA	30 ft	NA
One (1) No. 8 screw	60 ft	60 ft	60 ft	25 ft	50 ft	NA
Two (2) No. 8 screws	60 ft	60 ft	60 ft	60 ft	60 ft	50 ft
Hip Roofs Roof Slope: $> 2 \frac{1}{2} : 12$ and $\leq 6:12$						
Fastener Requirements	Mean Roof Height Limitation <sup>2</sup>					
	Inland II		Inland I		Seaward	
	Exposure B <sup>1</sup>	Exposure C <sup>1</sup>	Exposure B <sup>1</sup>	Exposure C <sup>1</sup>	Exposure B <sup>1</sup>	Exposure C <sup>1</sup>
Two (2) 10d nails	60 ft	60 ft	60 ft	50 ft	60 ft	20 ft
One (1) No. 8 screw	60 ft	60 ft	60 ft	60 ft	60 ft	50 ft
Two (2) No. 8 screws	60 ft	60 ft	60 ft	60 ft	60 ft	60 ft
Gable Roof Roof Slope: $> 6:12$ and $< 12:12$ <sup>3</sup>						
Fastener Requirements	Mean Roof Height Limitation <sup>2</sup>					
	Inland II		Inland I		Seaward	
	Exposure B <sup>3</sup>	Exposure C <sup>3</sup>	Exposure B <sup>3</sup>	Exposure C <sup>3</sup>	Exposure B <sup>3</sup>	Exposure C <sup>3</sup>
Two (2) 10d nails	60 ft	60 ft	60 ft	60 ft	60 ft	50 ft
One (1) No. 8 screw	60 ft	60 ft	60 ft	60 ft	60 ft	60 ft
Two (2) No. 8 screws	60 ft	60 ft	60 ft	60 ft	60 ft	60 ft
Monoslope Roof Roof Slope: $\geq 2 \frac{1}{2} : 12$ and $< 7:12$						
Fastener Requirements	Mean Roof Height Limitation <sup>2</sup>					
	Inland II		Inland I		Seaward	
	Exposure B <sup>3</sup>	Exposure C <sup>3</sup>	Exposure B <sup>3</sup>	Exposure C <sup>3</sup>	Exposure B <sup>3</sup>	Exposure C <sup>3</sup>
Two (2) 10d nails	60 ft	20 ft	40 ft	NA	NA	NA
One (1) No. 8 screw	60 ft	50 ft	60 ft	15 ft	NA	NA
Two (2) No. 8 screws	60 ft	60 ft	60 ft	60 ft	30 ft	NA

Note: <sup>1</sup>The Exposure category for the structure location shall be as defined in either the International Residential Code or the International Building Code.

<sup>2</sup>Table is based on an Importance Factor of 1.0

<sup>3</sup>Roof slopes greater than 7:12 require battens

**Table 10**  
**Saxony Country Slate-Impact**  
**(Roof Deck: Minimum 1 5/32" Plywood Deck – Batten Installation)**

Gable/Hip Roofs Roof Slope: $\geq 2 \frac{1}{2} : 12$ and $\leq 6:12$						
Fastener Requirements	Mean Roof Height Limitation <sup>2</sup>					
	Inland II		Inland I		Seaward	
	Exposure B <sup>1</sup>	Exposure C <sup>1</sup>	Exposure B <sup>1</sup>	Exposure C <sup>1</sup>	Exposure B <sup>1</sup>	Exposure C <sup>1</sup>
Two (2) 10d nails	NA	NA	NA	NA	30 ft	NA
One (1) No. 8 screw	30 ft	NA	NA	NA	NA	NA
Two (2) No. 8 screws	60 ft	15 ft	30 ft	NA	NA	NA
Hip Roofs Roof Slope: $> 2 \frac{1}{2} : 12$ and $\leq 6:12$						
Fastener Requirements	Mean Roof Height Limitation <sup>2</sup>					
	Inland II		Inland I		Seaward	
	Exposure B <sup>1</sup>	Exposure C <sup>1</sup>	Exposure B <sup>1</sup>	Exposure C <sup>1</sup>	Exposure B <sup>1</sup>	Exposure C <sup>1</sup>
Two (2) 10d nails	30 ft	NA	NA	NA	NA	NA
One (1) No. 8 screw	60 ft	25 ft	40 ft	NA	NA	NA
Two (2) No. 8 screws	60 ft	60 ft	60 ft	25 ft	50 ft	NA
Gable Roof Roof Slope: $> 6:12$ and $< 12:12$						
Fastener Requirements	Mean Roof Height Limitation <sup>2</sup>					
	Inland II		Inland I		Seaward	
	Exposure B <sup>1</sup>	Exposure C <sup>1</sup>	Exposure B <sup>1</sup>	Exposure C <sup>1</sup>	Exposure B <sup>1</sup>	Exposure C <sup>1</sup>
Two (2) 10d nails	60 ft	25 ft	40 ft	NA	NA	NA
One (1) No. 8 screw	60 ft	50 ft	60 ft	20 ft	40 ft	NA
Two (2) No. 8 screws	60 ft	60 ft	60 ft	50 ft	60 ft	25 ft
Monoslope Roof Roof Slope: $\geq 2 \frac{1}{2} : 12$ and $< 7:12$						
Fastener Requirements	Mean Roof Height Limitation <sup>2</sup>					
	Inland II		Inland I		Seaward	
	Exposure B <sup>1</sup>	Exposure C <sup>1</sup>	Exposure B <sup>1</sup>	Exposure C <sup>1</sup>	Exposure B <sup>1</sup>	Exposure C <sup>1</sup>
Two (2) 10d nails	NA	NA	NA	NA	NA	NA
One (1) No. 8 screw	NA	NA	NA	NA	NA	NA
Two (2) No. 8 screws	40 ft	NA	NA	NA	NA	NA

Note: <sup>1</sup>The Exposure category for the structure location shall be as defined in either the International Residential Code or the International Building Code.

<sup>2</sup>Table is based on an Importance Factor of 1.0

**Table 11**  
**Barcelona - Impact**  
**(Roof Deck: Minimum  $1\frac{5}{32}$ " Plywood Deck without Battens)**

<b>Gable Roofs</b>						
<b>Roof Slope: <math>\geq 2\frac{1}{2}</math>:12 and <math>\leq 6</math>:12</b>						
Fastener Requirements	Mean Roof Height Limitation <sup>2</sup>					
	Inland II		Inland I		Seaward	
	Exposure B <sup>1</sup>	Exposure C <sup>1</sup>	Exposure B <sup>1</sup>	Exposure C <sup>1</sup>	Exposure B <sup>1</sup>	Exposure C <sup>1</sup>
Two (2) 10d Ring Shank Nails	N/A	N/A	N/A	N/A	N/A	N/A
Two (2) No. 9 x 3" Screws	60 ft	60 ft	60 ft	60 ft	60 ft	50 ft
<b>Gable Roofs</b>						
<b>Roof Slope: <math>&gt; 6</math>:12 and <math>\leq 7</math>:12<sup>3</sup></b>						
Fastener Requirements	Mean Roof Height Limitation <sup>2</sup>					
	Inland II		Inland I		Seaward	
	Exposure B <sup>1</sup>	Exposure C <sup>1</sup>	Exposure B <sup>1</sup>	Exposure C <sup>1</sup>	Exposure B <sup>1</sup>	Exposure C <sup>1</sup>
Two (2) 10d Ring Shank Nails	60 ft	40 ft	60 ft	15 ft	35 ft	N/A
Two (2) No. 9 x 3" Screws	60 ft	60 ft	60 ft	60 ft	60 ft	60 ft

Note: <sup>1</sup> The Exposure category for the structure location shall be as defined in either the International Residential Code or the International Building Code.

<sup>2</sup> Table is based on an Importance factor of 1.0

<sup>3</sup> Roof slopes greater than 7:12 require battens

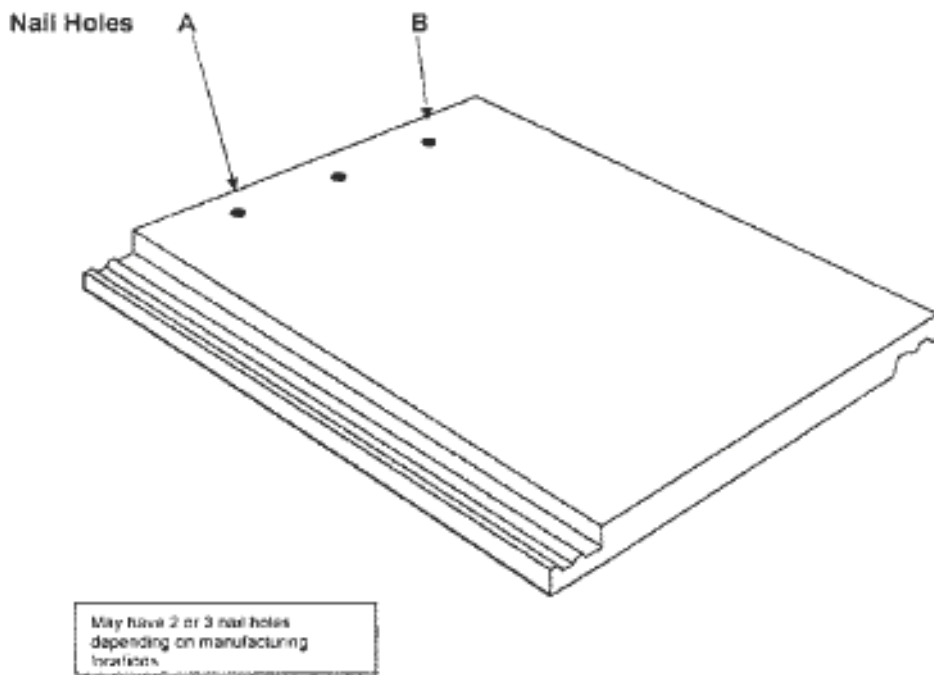

Figure 1: Representative Saxony Tile

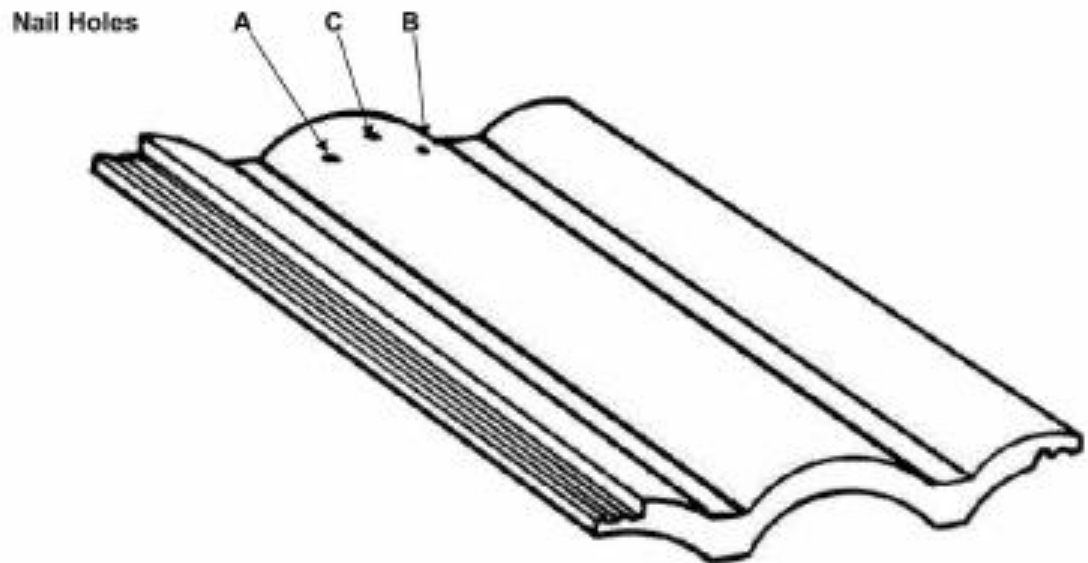

Figure 2: Representative Villa Tile

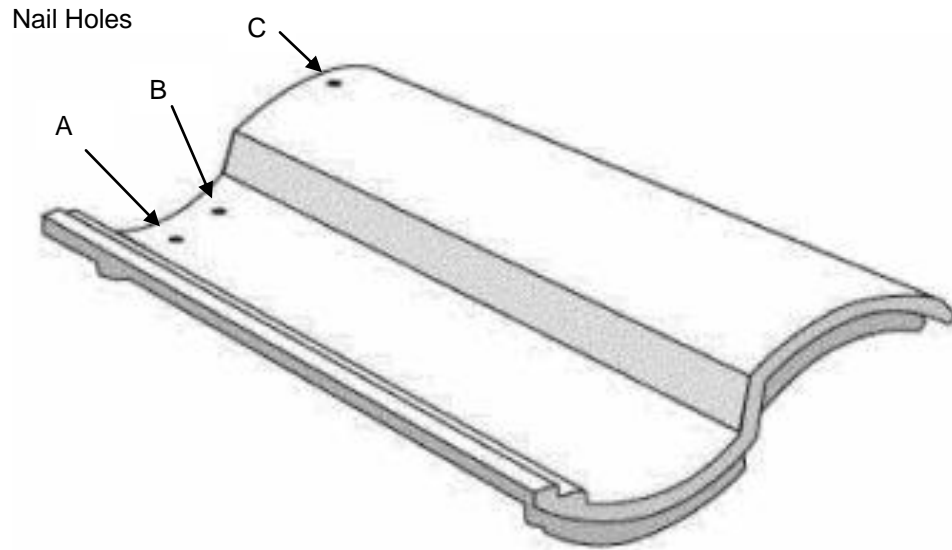

Figure 3: Representative Tejas Espana and Barcelona – Impact Tile

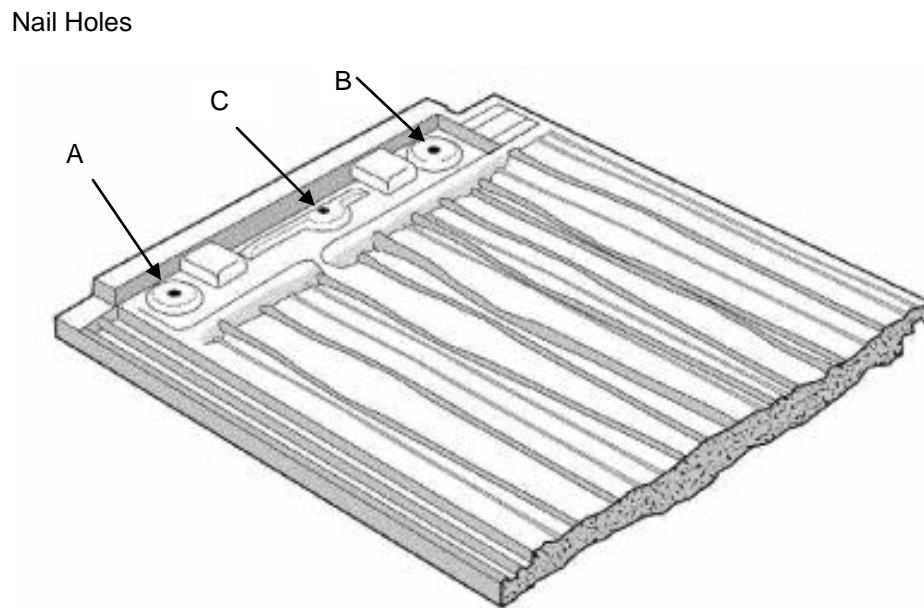

Figure 4: Representative Madera Tile

Nail Holes

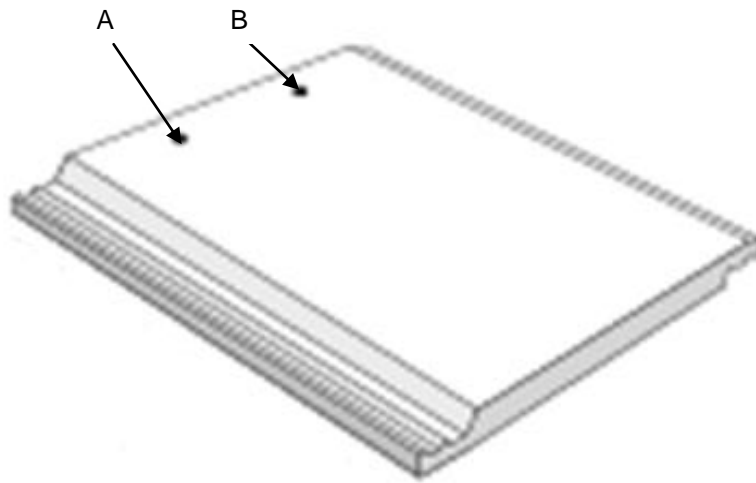

Figure 5 – Representative Saxony Country Slate-Impact