



DEPARTMENT OF REGULATORY AND ECONOMIC RESOURCES (RER)
BOARD AND CODE ADMINISTRATION DIVISION

MIAMI-DADE COUNTY
PRODUCT CONTROL SECTION
11805 SW 26 Street, Room 208
Miami, Florida 33175-2474
T (786) 315-2590 F (786) 315-2599
www.miamidade.gov/economy

NOTICE OF ACCEPTANCE (NOA)

Boral Roofing, LLC
7575 Irvine Center Drive, Suite 100
Irvine, CA 92618

SCOPE:

This NOA is being issued under the applicable rules and regulations governing the use of construction materials. The documentation submitted has been reviewed and accepted by Miami-Dade County RER - Product Control Section to be used in Miami-Dade County and other areas where allowed by the Authority Having Jurisdiction (AHJ).

This NOA shall not be valid after the expiration date stated below. The Miami-Dade County Product Control Section (in Miami-Dade County) and/or the AHJ (in areas other than Miami-Dade County) reserve the right to have this product or material tested for quality assurance purposes. If this product or material fails to perform in the accepted manner, the manufacturer will incur the expense of such testing and the AHJ may immediately revoke, modify, or suspend the use of such product or material within their jurisdiction. RER reserves the right to revoke this acceptance, if it is determined by Miami-Dade County Product Control Section that this product or material fails to meet the requirements of the applicable building code.

This product is approved as described herein, and has been designed to comply with the Florida Building Code including the High Velocity Hurricane Zone of the Florida Building Code.

DESCRIPTION: Barcelona 900 Concrete Roof Tile

LABELING: Each unit shall bear a permanent label with the manufacturer's name or logo, city, state and following statement: "Miami-Dade County Product Control Approved", unless otherwise noted herein.

RENEWAL of this NOA shall be considered after a renewal application has been filed and there has been no change in the applicable building code negatively affecting the performance of this product.

TERMINATION of this NOA will occur after the expiration date or if there has been a revision or change in the materials, use, and/or manufacture of the product or process. Misuse of this NOA as an endorsement of any product, for sales, advertising or any other purposes shall automatically terminate this NOA. Failure to comply with any section of this NOA shall be cause for termination and removal of NOA.

ADVERTISEMENT: The NOA number preceded by the words Miami-Dade County, Florida, and followed by the expiration date may be displayed in advertising literature. If any portion of the NOA is displayed, then it shall be done in its entirety.

INSPECTION: A copy of this entire NOA shall be provided to the user by the manufacturer or its distributors and shall be available for inspection at the job site at the request of the Building Official.

This NOA renews NOA No.12-0222.02 and consists of pages 1 through 7.
The submitted documentation was reviewed by Alex Tigera.



NOA No.: 16-0711.01
Expiration Date: 04/26/22
Approval Date: 10/27/16
Page 1 of 7

ROOFING ASSEMBLY APPROVAL

Category: Roofing
Sub-Category: Roofing Tiles
Material: Concrete

1. SCOPE

This approves a roofing system using **Barcelona 900 Concrete Roof Tile**, as manufactured **Boral Roofing LLC** in **Lake Wales, FL** and described this Notice of Acceptance. For locations where the pressure requirements, as determined by applicable Building Code, do not exceed the design pressure values obtained by calculations in compliance with RAS 127 using the values listed in the installation section herein. The attachment calculations shall be done as a moment based system.

2. PRODUCT DESCRIPTION

<u>Manufactured by Applicant</u>	<u>Dimensions</u>	<u>Test Specifications</u>	<u>Product Description</u>
Barcelona 900	Length = 17" Width = 13" ½" thick	TAS 112 Type – 1a	High profile, interlocking, one-piece, 'S' shaped, high-pressure extruded concrete roof tile equipped with three nail holes. For direct deck or battened nail-on, mechanically fastened, mortar set or adhesive set applications.
Trim Pieces	Length: varies Width: varies varying thickness	TAS-112	Accessory trim, boosted Barcelona, concrete roof pieces for use at hips, rakes, ridges and valley terminations manufactured for each tile profile.

2.1 MANUFACTURING LOCATION

2.1.1. Lake Wales, FL

2.2 SUBMITTED EVIDENCE:

<u>Test Agency</u>	<u>Test Identifier</u>	<u>Test Name/Report</u>	<u>Date</u>
Redland Technologies	7161-03 Appendix III	Static Uplift Testing TAS 102 & TAS 102(A)	Dec. 1991
Redland Technologies	7161-03 Appendix II	Wind Tunnel Testing TAS 108(Nail-On)	Dec. 1991
Redland Technologies	P0402	Withdrawal Resistance Testing of screw vs. smooth shank nails	Sept. 1993
Redland Technologies	Letter Dated Aug. 1, 1994	Wind Tunnel Testing TAS 108 (Nail-On)	Aug. 1994
Redland Technologies	P0631-01	Wind Tunnel Testing TAS 108 (Mortar Set)	July 1994



NOA No.: 16-0711.01
 Expiration Date: 04/26/22
 Approval Date: 10/27/16
 Page 2 of 7

Professional Service Industries, Inc.	IC-1320-94	Physical Properties TAS 112	Feb. 1995
The Center for Applied Engineering, Inc.	25-7688-3	TAS 101 (Adhesive Set)	June 1996
	25-7688-10	TAS 101 (Mortar Set)	July 1996
The Center for Applied Engineering, Inc.	25-7688-5	Static Uplift Testing TAS 102 (3" Headlap, Nails, Direct Deck, New Construction)	June 1996
The Center for Applied Engineering, Inc.	25-7688-4	Static Uplift Testing TAS 102 (4" Headlap, Nails, Clips)	June 1996
Celotex Corporation	520111-3	Static Uplift Testing	Dec. 1998
Testing Services	520191-2-1	TAS 101	March 1999
Walker Engineering, Inc.	Calculations	Aerodynamic Multiplier	09/01/16
Walker Engineering, Inc.	Evaluation Calculations	Restoring Moments Due to Gravity	09/01/16
American Test Lab of South Florida	RT0617.03-16	TAS 112	06/29/16

3. LIMITATIONS:

- 3.1 Fire classification is not part of this acceptance.
- 3.2 For mortar or adhesive set tile applications, a static field uplift test in accordance with TAS 106 may required, refer to applicable building code.
- 3.3 Applicant shall retain the services of a Miami-Dade County Certified Laboratory to perform quarterly test in accordance with TAS 112, appendix 'A'. Such testing shall be submitted to the Department of Regulatory and Economic Development – Product Control Section for review.
- 3.4 Minimum underlayment shall be in compliance with the applicable Roofing Applications Standards listed section 4.1 herein.
- 3.5 30/90 hot mopped underlayment applications may be installed perpendicular to the roof slope unless stated otherwise by the underlayment material manufacturers published literature.
- 3.6 This acceptance is for wood deck applications. Minimum deck requirements shall be in compliance with applicable building code.



4. INSTALLATION

- 4.1 Barcelona 900 Concrete Roof Tile and its components shall be installed in strict compliance with Roofing Application Standard RAS 118, RAS 119, and RAS 120.
- 4.2 Data For Attachment Calculations

Table 1: Average Weight (W) and Dimensions (l x w)

Tile Profile	Weight-W (lbf)	Length-l (ft)	Width-w (ft)
Barcelona 900	11.5	1.417	1.08

Table 2: Aerodynamic Multipliers - λ (ft³)

Tile Profile	λ (ft ³) Batten Application	λ (ft ³) Direct Deck Application
Barcelona 900	0.286	0.301

Table 3: Restoring Moments due to Gravity - M_g (ft-lbf)

Tile Profile	2":12"		3":12"		4":12"		5":12"		6":12"		7":12" or greater	
	Battens	Direct Deck	Battens	Direct Deck	Battens	Direct Deck	Battens	Direct Deck	Battens	Direct Deck	Battens	Direct Deck
Barcelona 900	6.19	7.07	6.19	7.00	6.19	6.90	6.06	6.76	5.92	6.60	5.76	6.42

Table 4: Attachment Resistance Expressed as a Moment - M_f (ft-lbf) for Mechanically Attached Systems

Tile Profile	Fastener Type	Direct Deck (min 15/32" plywood)	Direct Deck (min. 19/32" plywood)	Battens
Barcelona 900	2-10d Ring Shank Nails	28.6	41.2	19.4
	1-10d Smooth or Screw Shank Nail	5.1	6.8	2.8
	2-10d Smooth or Screw Shank Nails	6.9	9.2	7.3
	1 #8 Screw	20.7	20.7	18.1
	2 #8 Screw	43.2	43.2	29.8
	1-10d Smooth or Screw Shank Nail (Field Clip)	23.1	23.1	19.0
	1-10d Smooth or Screw Shank Nail (Eave Clip)	29.3	29.3	24.0
	2-10d Smooth or Screw Shank Nails (Field Clip)	27.6	27.6	38.6
	2-10d Smooth or Screw Shank Nails (Eave Clip)	38.1	38.1	41.8

**Table 5: Attachment Resistance Expressed as a Moment - M_f (ft-lbf)
for Mechanically Attached Systems**

Tile Profile	Fastener Type	Direct Deck (min 15/32" plywood)	Direct Deck (min. 19/32" plywood)	Battens
Barcelona 900	2-10d Ring Shank Nails ¹	33.1	48.1	45.2

¹ Installation with a 4" tile headlap and fasteners are located a min. of 2½" from head of tile.

**Table 6: Attachment Resistance Expressed as a Moment M_f (ft-lbf)
for Two Paddy Adhesive Set Systems**

Tile Profile	Tile Application	Minimum Attachment Resistance
Barcelona 900	Adhesive ¹	29.3 ²

¹ See manufactures component approval for installation requirements.

² TILE BOND™ Roof Tile Adhesive; Average weight per paddy 10.7 grams.
ICP Adhesives and Sealants, Inc.'s ICP Adhesives Polyset AH-160; Average weight per paddy 8 grams.

**Table 7: Attachment Resistance Expressed as a Moment - M_f (ft-lbf)
for Single Paddy Adhesive Set Systems**

Tile Profile	Tile Application	Minimum Attachment Resistance
Barcelona 900	ICP Adhesives Polyset AH-160	66.5 ³
	ICP Adhesives Polyset AH-160	38.7 ⁴

³ Large paddy placement of 63 grams of ICP Adhesives and Sealants, Inc.'s ICP Adhesives Polyset AH-160.

⁴ Medium paddy placement of 24 grams of ICP Adhesives and Sealants, Inc.'s ICP Adhesives Polyset AH-160.

**Table 8: Attachment Resistance Expressed as a Moment - M_f (ft-lbf)
for Mortar Set Systems**

Tile Profile	Tile Application	Attachment Resistance
Barcelona 900	Mortar Set ⁵	24.5

⁶ See specific mortar manufacturers Notice of Acceptance



5. LABELING

- 5.1 All tiles shall bear the imprint or identifiable marking of the manufacturer's name or logo as detailed below, or following statement: "Miami-Dade County Product Control Approved".

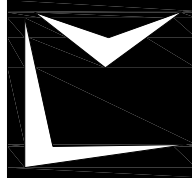

LABEL FOR BARCELONA 900 TILE (LAKE WALES FL PLANT 2) LOCATED UNDERNEATH TILE

6. BUILDING PERMIT REQUIREMENTS

- 6.1 Application for building permit shall be accompanied by copies of the following:
- 6.1.1 This Notice of Acceptance.
 - 6.1.2 Any other documents required by the Building Official or applicable building code in order to properly evaluate the installation of this system.

PROFILE DRAWING

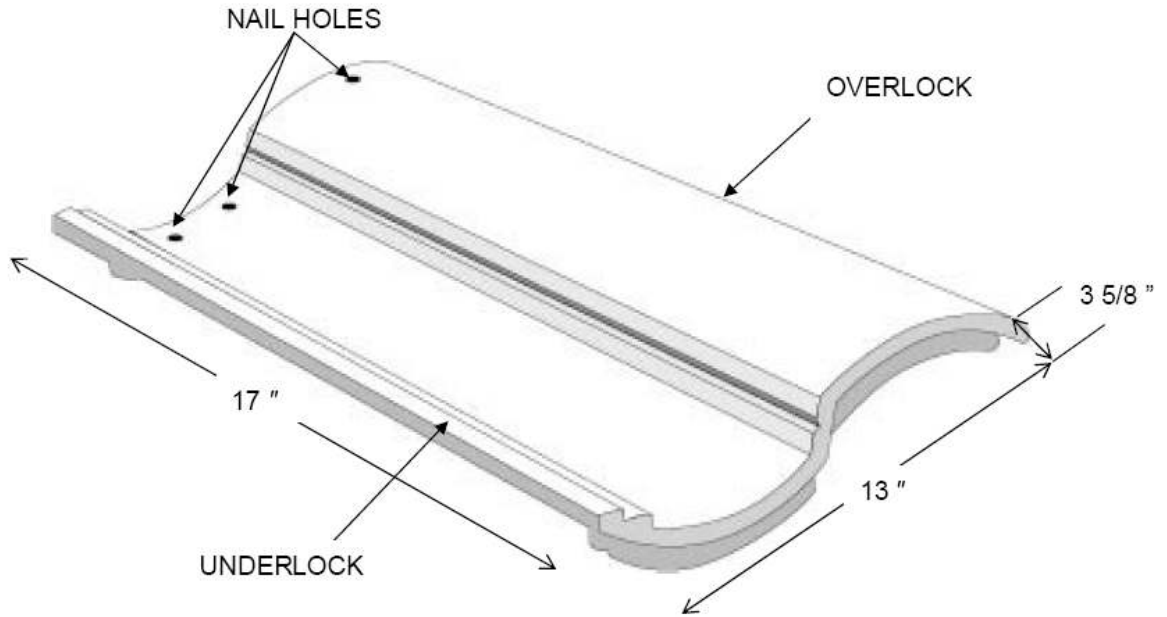

BARCELONA 900 CONCRETE ROOF TILE

END OF THIS ACCEPTANCE